

# American Holtekraft

## UMBRELLA STAND SERIES



#602  
57 LBS.  
24 1/2" DIA.  
3/8" THICK



#601  
71 LBS.  
21 3/4" SQ.  
1/2" THICK



#603  
138 LBS.  
30" SQ.  
1/2" THICK



### DESIGN FEATURES

- Two-piece construction assembles easily with one carriage bolt.
- Thru holes are provided near the top of the sleeve for securing the umbrella to the stand with a restraint pin or bolt. (See note below.)
- A drainage hole at the bottom of sleeve eliminates water buildup.
- Four 3/8" diameter holes are provided in the base plate for securing the stand to the deck or surface on which it rests. (See note below.)
- Thick durable feet made of long lasting tested molded Polypropylene provide protection against surface scratches and keeps base plate off of the ground, minimizing moisture buildup.
- Heavy steel construction provides sound umbrella support.
- Standard painted finishes in black, white, and almond.

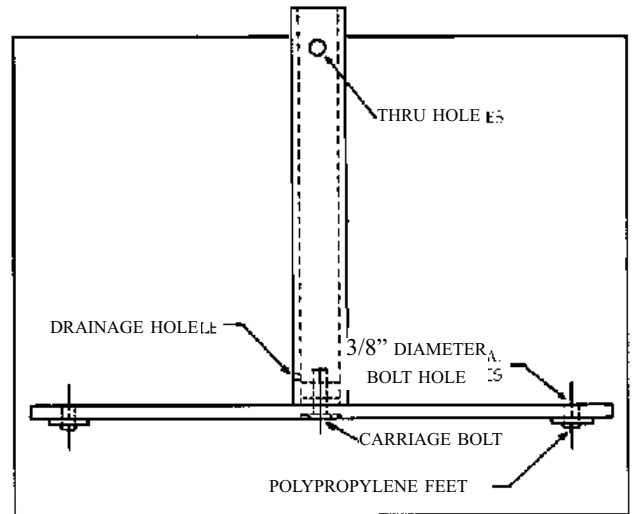

### STAND OPTIONS

- Three stands to choose from. (See above.) Ask a representative which base is right for you.
- Three sleeve sizes for 1 1/2", 2", 2 3/8" diameter poles.
- Available in white, almond or black powder coat.

**NOTE: READ AND FOLLOW INSTRUCTIONS INCLUDED WITH STAND.**

